

**OUR HEAD OFFICE AND PLANT ARE CERTIFIED
TO BOTH ISO 9001 AND ISO 14001.**

Niigata plant:

Shimo Aozu, Tsubame-city, Niigata-prefecture, Japan.



ISO9001 : JQA-0581
ISO14001 : JQA-EM4670

SAFETY

- Operate safely in accordance with proper operation manual.
- To prevent trouble and accidents, perform daily and preventive maintenance checks without fail.

AIRMAN®

HOKUETSU INDUSTRIES CO., LTD.

8th Floor Shinjuku San-Ei Bldg,
22-2 Nishi-Shinjuku 1-Chome, Shinjuku-ku, Tokyo 160-0023 Japan
Tel: 81-3-3348-7281 Fax: 81-3-3348-7289
E-mail: airman.oversea@airman.co.jp
<http://www.airman.co.jp>

AIRMAN ASIA SDN. BHD.

Suite A-8-2, level 8, Block A, Sky Park @ One City,
Jalan USJ 25/1, 47650 Subang Jaya, Selangor, Malaysia
Tel: 60-3-5036-7228 Fax: 60-3-5036-7226
E-mail: sales@airman-asia.com

HOKUETSU INDUSTRIES EUROPE B.V.

Aalsmeerderdijk 156, 1438 AX Oude Meer, The Netherlands
Tel: 31-20-6462636 Fax: 31-20-6462191
E-mail: info@hokuetsu.nl

AIRMAN USA CORPORATION

7633 Adairsville Hwy Adairsville, GA 30103
Tel: 1-770-769-4241 Fax: 1-770-769-4335

DISTRIBUTOR :

**Engine GENERATOR
SDG series**

AIRMAN®



**Engine GENERATOR
SDG series
10.5 ~ 610kVA**



SDG25S



Environmental Containment Onsite Type
SDG150S-F

"AIRMAN" MOST ADVANCED GENERATOR

Applicable for every field and jobsite!!
Further environment friendly!!

Environmental
Containment Onsite Type

10.5 ~ 220kVA
SDG-F series

Features
and
benefits

Continuous operation for the time from
1 day & half ~ 3 days

A big capacity fuel tank equipped as a standard one enables long continuous operation without any additional fuel tank provided.

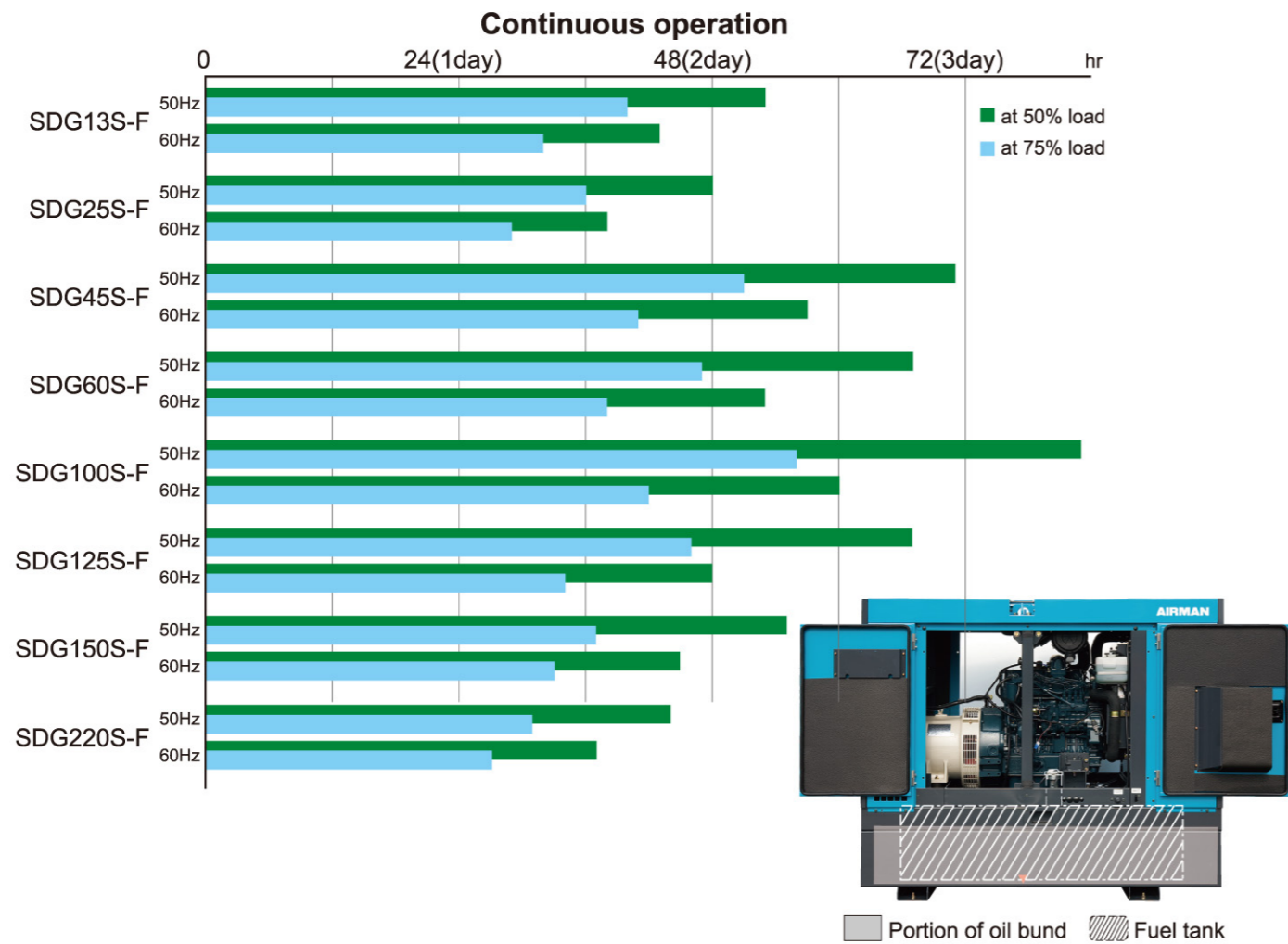

● **Separate oil bund is not required**

No separate oil bund is required for the generator as well as the additional fuel tank.

● **Additional fuel tank is not required**

No potential fuel leakage along the interconnecting pipes.

● **Rain water ingress is minimized**

Rainwater will not be collected like traditional oil bund as it is fully integrated within the enclosure package.

● **Complete package is fully transportable**

Without separate fuel tank and oil bund, the fully integrated generator with long-range tank and integrated bund is fully transportable as one package.

Convention package

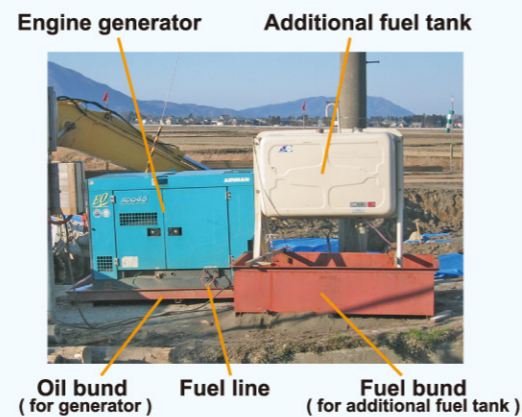

*Oil bund and Oil Fence are same meaning



Features
and
benefits

Specially designed construction for prevention of rain penetration

Unlike separate fuel bund and generator oil bund, Airmar's fully bundled with extended tank minimize any potential of rain water penetration into the bund and minimize the maintenance work required.

● **Prevention of rain penetration**

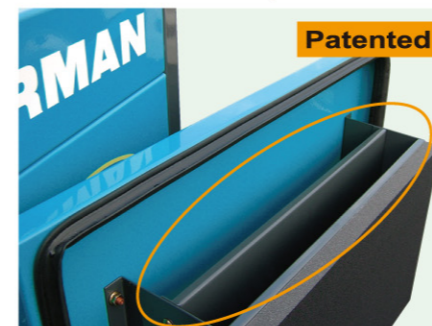

Air inlet port is specially designed to increase intake air and to reduce the suction pressure inside to minimize the potential rain water penetration.

● **Prevention of rain infiltration**

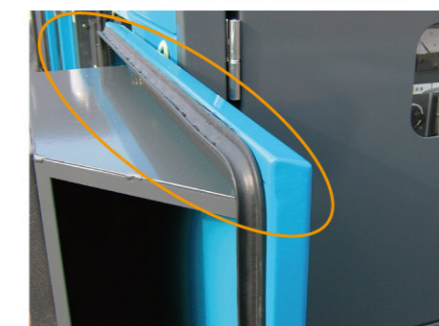

Insert type seal which is usually used for automobile is adopted so that rain penetration can be avoided.

● **Prevention of water and oil leak**

For the series from SDG13 to SDG60, the portions of oil fence are formed by bending so that welding work is minimized. Further, air tight welding work is continuously performed on welded portions.



Double wall steel fuel tanks have 110% fluid capacity containment.

● **Facilitated maintenance**



Utility model

Oil fence can be easily removed and reinstalled by removing the stud bolts (4 ~ 8 pieces).



Fuel tank is provided with lifting hooks as standard.

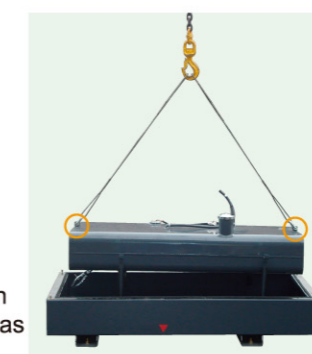

● **Warning indicator**

The warning lamp on the panel goes on when oil / water is filled in the oil bund.

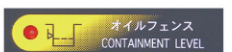

High Generating Performance

Better Generating Performance

SDG series generators are coupled to low transient reactance alternator and reinforced damper coil. This increases the negative-phase-sequence current capability and minimizes the output waveform distortion. Therefore, they are suitable for wide range of non-linear load such as inverter, thyristor, computer control, discharge lighting, precision instruments and instrumental device.

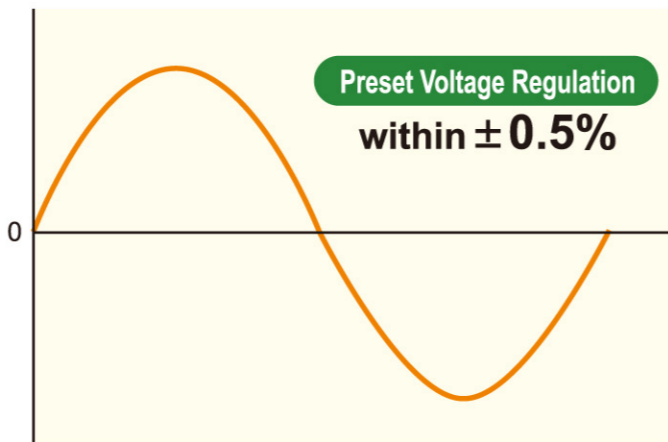

Environmental Friendly

Low Noise Level

Operating noise has been minimized with low noise engines, equipped with highly attenuated muffler and special exhaust system design. All SDG models (excluding SDG100S) are adopted panel structure to minimize structural clearance and reduce internal space. Combined inlet duct design further reduces the overall noise level.

Exhaust muffler system is mounted on special design support structure to reduce vibration.

Super Silent
SDG13S~220S

Ultra Super Silent
SDG25AS~150AS



Silent
SDG300S~610S

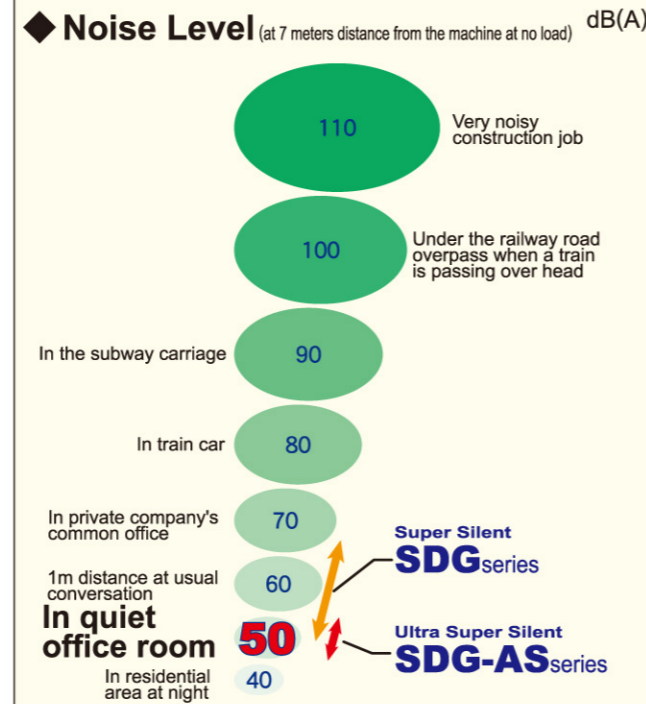

Blowby Gas (SDG13~100, 125S-F, 150S-F)

The generators have been newly designed to circulate the blowby gas inside the machine (PCV system). They are driven by such environmental friendly engine to keep the generator outside as well as the inside from being stained.

Fully Equipped

Dual Voltage Models

By changing over the short connecting plate in the control panel, the three phase output voltage can be switched to 200/220V from 400(380)/440V and vice versa.

When starting engine, the indication lamp at the operation panel goes on to display the operating voltage immediately.

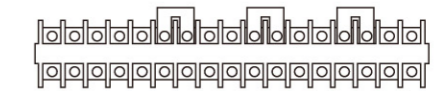
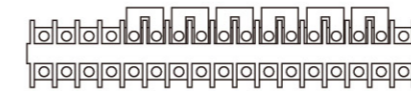
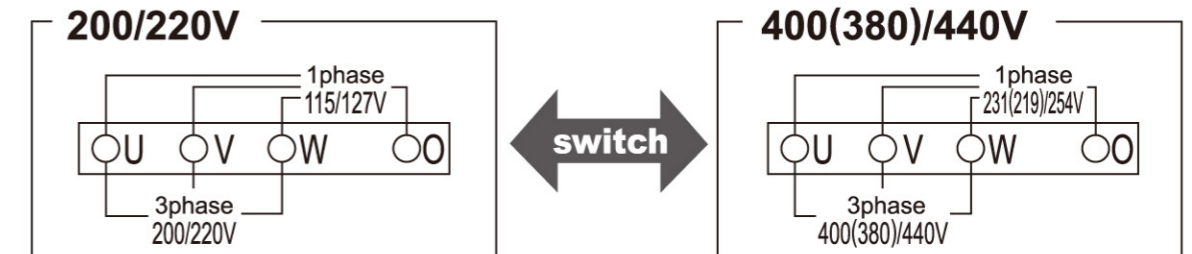

Continuous Operation available for a long time

A large capacity fuel tank and low fuel consumption engine have made the generators run continuously for a long time.

Also for SDG13S~610S three-way selection valve is provided as a standard equipment to be easily connected to an additional outside fuel tank. One way selection method by one selection lever avoids wrong operation when changing over suction side to return side and vice versa.



In case the mounted fuel tank is used

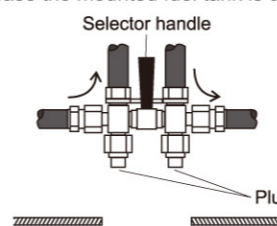

Engine being fueled by separate fuel tank

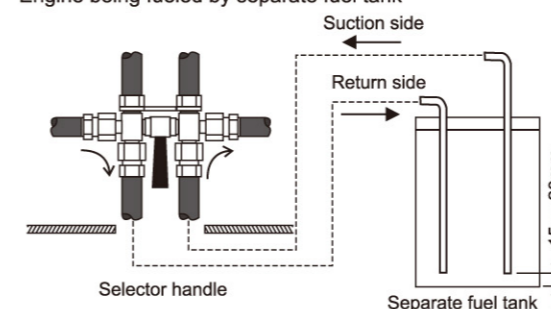

Automatic Air Bleeding System (SDG13~150)

Automatic Air Bleeding Device is equipped to automatically bleed air from fuel line system. This eliminates the need to prime the fuel system again should the generator be shutdown due to running out of fuel. Simply top up the fuel and turn the key switch to operation position, air in the fuel line system is bled automatically. As for both SDG125S/150S/150AS, it is possible to automatically bleed air by pushing the push button provided at the operation panel.



Parallel Operation (SDG125, 150S/AS, 610S)

High Accurate Parallel Operation System (CCR cross current prevention device) is provided as a standard equipment. Combined with an accurate AVR (automatic voltage regulator), it is possible to perform parallel operation manually.



Easy Maintenance

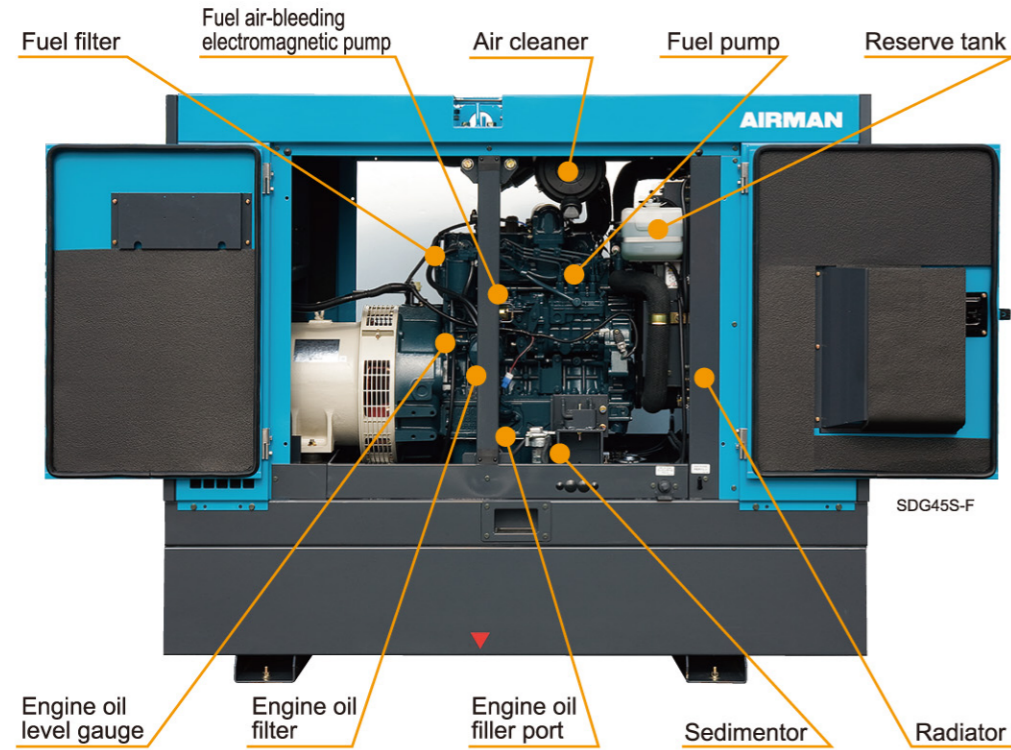

Maintenance with Great Ease

Daily inspection such as engine oil and coolant level can be done by opening the right side door.

For SDG45 & 60, one battery of two mounted batteries has been eliminated, thus dedicated to reducing industrial waste and maintenance cost.

Mounting and Demounting Fuel Tank

Mounting and demounting fuel tank has been made easier by making the bottom floor entirely flat. It is easy to clean the interior by removing the fuel tank.

Inspection and Cleaning Radiator

For SDG series inspection of radiator and cleaning radiator can be easily performed by removing both side front covers and dividable fan shrouds.



Maintenance Cycle

Model	Engine oil	Oil filter	Fuel filter	Air element
SDG13,25,220	250 *1	500 *1	500	1,000
SDG45~150	500 *1	500 *1	500	1,000
SDG300	250 *1	250 *1	500	1,000
SDG400,500,610	500 *2	500 *2	500	1,000

*1 For the items marked with a asterisk, first run in oil / filter change 50hr. *2 For the items marked with a asterisk, first run in oil / filter change 250hr.

Flat Frame (SDG13~610, excluding 60AS/100S/150AS)

The interior of the machine is flatly constructed so as to be easily cleaned.

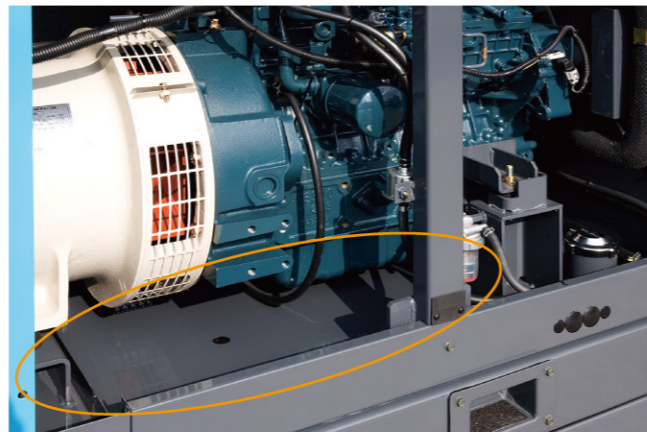

Newly-Designed Panel Construction

(excluding 100S)

The bonnet is of panel constructed type for easily dismantling and assembling for maintenance.

Operation

Engine Starting Efficiency

For SDG13~220, engine preheating system consists of quick heating glow plug to easily start up engine in low temperature conditions.

SDG220~610 are driven by high start-up engine which exercises great power for earth auger and vibro-hammer operations requiring instant electric flow. Start-up characteristics have been more improved for electric motor start-up as well as turbo charger and governor improved.

Control Panel

Control devices for generator and electrical appliances for engine are concentrated inside the control panel for better maintenance.

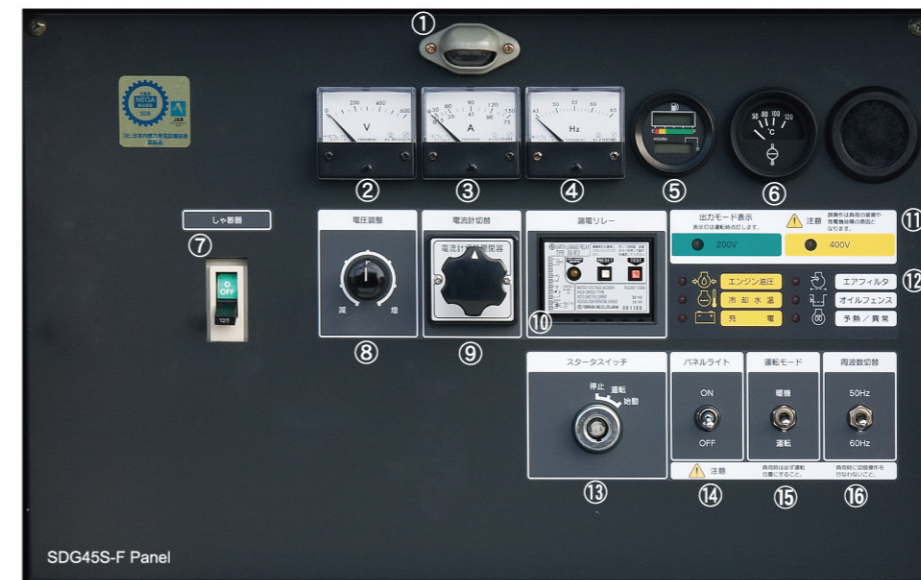

- ① Panel light
- ② Voltmeter
- ③ Ammeter
- ④ Frequency meter
- ⑤ Fuel gauge with hour meter
- ⑥ Water temperature meter
- ⑦ Three phase circuit breaker
- ⑧ Voltage regulator
- ⑨ Current selector switch
- ⑩ Leakage relay
- ⑪ Output indicator lamp
- ⑫ Warning lamps (For details, see the followings)
- ⑬ Starter switch
- ⑭ Panel light switch
- ⑮ Operation mode selection switch
- ⑯ Frequency selection switch

Electronic Governor

(SDG13~45,100S-F~150S-F,220,400,500,610)

Stable engine speed can be secured because engine speed is made easier to be adjusted.

It is possible to select frequency and make fine adjustment of engine speed only by moving up and down "Switch for fine adjustment of engine speed". It is also possible easily to perform "Idling ⇄ Operation" with the slowdown switch.

Safety

Completely Monitoring System

For SDG60~150, 300S,610S in order to eliminate the electric fault when restarting engine, they are provided with shunt trip as standard equipment to trip the main circuit breaker in case of emergency shutdown. If electric fault occurs, the warning lamp goes on and opens the generator breaker.

Warning Lamps & Emergency Stop

Model	Oil press. Drop	Water temp. rise	Over Speed	Overcurrent, Short-circuit	Electric Leakage	Faulty Battery charging	Air filter Clogging
SDG13~45	■	■	■	*1	□*1	■	□
SDG60~150,300,610	■*1	■*1	■*1	*1	□*1	□	□
SDG100S-F~220S-F SDG220,400,500	■	■	■	*1	□*1	□	□

■ Warning lamp goes on and it causes Engine emergency stop

□ Warning lamp goes on

*1 Breaker OFF



SDG13S



SDG25S



SDG45S



SDG220S



SDG300S



SDG60S



SDG100S



SDG125S/150S



SDG400S



SDG500S



SDG610S

■ SPECIFICATIONS

Model	SDG13S -3B1		SDG25S -3B1		SDG45S -3A8		SDG60S -3A6		SDG100S -3A5		SDG125S -3A6		SDG150S -3A6		
● Generator															
Frequency	Hz	50	60	50	60	50	60	50	60	50	60	50	60	50	60
Rated Output	kVA	10.5	13	20	25	37	45	50	60	80	100	100	125	125	150
Voltage	V	50Hz : 200 or 380 or 400 or 415 , 60Hz : 220 or 440(Dual Voltage)													
Power Factor	%	80													
Class of rating		Continuous													
Exciting Method		Brushless (with A.V.R.)													
No. of Phase		3-Phase,4-Wire													
● Diesel Engine															
Make and Model		Kubota D1503-K3A		Kubota V2403-K3A		Kubota V3800-DI-T-K2B		Isuzu BB-4BG1T		Isuzu DD-6BG1T		Hino J08C-UP		Hino J08C-UD	
No. of Cylinder		3		4		4		4		6		6		6	
Type(4Cycle,Water-Cooled)		Swirl Chamber				Direct Injection,Turbo charged						Direct Injection, Turbo charged,Intercooled			
Total Displacement	L	1.499		2.434		3.769		4.329		6.494		7.961		7.961	
Rated Output	PS(kW)	15.6(11.5)	18.6(13.7)	26(19.1)	32(23.7)	51.7(38.0)	62(45.6)	65.4(48.1)	78(57.4)	100(73.6)	124(91.2)	131(96.3)	153(112.7)	160(118)	190(140)
Speed	rpm	1,500	1,800	1,500	1,800	1,500	1,800	1,500	1,800	1,500	1,800	1,500	1,800	1,500	1,800
Fuel		Diesel Fuel Oil													
Fuel Tank Capacity	L	58		70		100		135		225		250		250	
Fuel Consumption(50/75%Load)	L/hr	1.8/2.4	2.2/3.0	3.0/4.0	3.8/5.0	4.4/6.4	5.5/8.0	6.0/8.6	7.5/10.5	10.2/14.5	13.2/19.0	11.5/16.4	15.3/21.0	14.7/19.4	17.7/24.3
Lubricating Oil Capacity	L	6.5		9.5		13.2		14		18		24.5		24.5	
Cooling Water Capacity	L	5.7		7.0		11		15		24		22		22	
Battery(Capacity 5hrs)	(Ah)	80D26R(55)×1		80D26R(55)×1		80D26R(55)×1		80D26R(55)×1		95D31R(64)×2		95D31R(64)×2		95D31R(64)×2	
● Dimensions & Weight															
Overall Length	mm	1,480		1,550		1,870		2,090		2,600		2,990		2,990	
Overall Width	mm	650		700		860		860		1,000		1,180		1,180	
Overall Height	mm	950		980		1,220		1,220		1,400		1,480		1,480	
Net Dry Mass	kg	520		610		900		1,120		1,640		2,050		2,180	
Operating Mass	kg	580		680		1,010		1,260		1,870		2,300		2,430	
● Sound Level															
Sound power level in decibels	dB	83		90		87		90		91		92		94	
Sound pressure level*1	dB(A)	56	57	59	63	57	60	59	63	61	64	63	65	63	66

* For other voltages than above-mentioned ones, contact us.

*1 7m in four directions from machine and at no load

■ SPECIFICATIONS

Model	SDG220S -3A6		SDG300S -3A6		SDG400S -3A6 [-3A7]		SDG500S -3A6		SDG610S -3AK6		
● Generator											
Frequency	Hz	50	60	50	60	50	60	50	60	50	60
Rated Output	kVA	200	220	270	300	350	400	450	500	555	610
Voltage	V	50Hz : 200 or 380 or 400 or 415 , 60Hz : 220 or 440 (Dual Voltage)									
Power Factor	%	80									
Class of rating		Continuous									
Exciting Method		Brushless (with A.V.R.)									
No. of Phase		3-Phase,4-Wire									
● Diesel Engine											
Make and Model		Mitsubishi 6D24-TLE2B		Komatsu SAA6D125E-2-B		Komatsu SA6D140E-3-A		Komatsu SAA6D140E-3-B		Komatsu SA6D170-A-1	
No. of Cylinder		6									
Type(4Cycle,Water-Cooled)		Direct Injection,Turbo charged,Intercooled				Direct Injection,Turbo charged		Direct Injection, Turbo charged,Intercooled		Direct Injection,Turbo charged	
Total Displacement	L	11.94		11.04		15.24		15.24		23.15	
Rated Output	PS(kW)	246(181)	270(199)	315(232)	349(257)	421(310)	485(357)	519(382)	581(427)	669(485)	763(561)
Speed	rpm	1,500	1,800	1,500	1,800	1,500	1,800	1,500	1,800	1,500	1,800
Fuel		Diesel Fuel Oil									
Fuel Tank Capacity	L	390		490		490		490		490	
Fuel Consumption(50/75%Load)	L/hr	22.5/31.8	26.2/36.3	30.0/43.1	34.3/50.6	39.7/56.6	46.7/65.3	48.4/69.2	55.3/78.3	61.8/87.5	71.7/101.2
Lubricating Oil Capacity	L	37		62		79		91.5		119	
Cooling Water Capacity	L	39		43.5		69		91.5		141	
Battery(Capacity 5hrs)	(Ah)	170F51(120)×2		170F51(120)×2		225H52(176)×2		225H52(176)×2		225H52(176)×2	
● Dimensions & Weight											
Overall Length	mm	3,700		3,900		4,150		4,550		4,650	
Overall Width	mm	1,300		1,400		1,400		1,600		1,600	
Overall Height	mm	1,670		1,760		2,040		2,090		2,350	
Net Dry Mass	kg	3,240		3,790		5,120 [5,050]		6,170		7,320	
Operating Mass	kg	3,630		4,290		5,670 [5,590]		6,750		7,960	
● Sound Level											
Sound power level in decibels	dB	94		98		99		99		102	
Sound pressure level*1	dB(A)	65	65	66	69	67	70	67	70	69	72

* For other voltages than above-mentioned ones, contact us.

*1 7m in four directions from machine and at no load

Environmental Containment Onsite Type SDG-F Series



■ SPECIFICATIONS

Model	SDG13S -7B1		SDG25S -7B1		SDG45S -7A8		SDG60S -7A6		SDG100S -7B1		SDG125S -7B1		SDG150S -7B1		SDG220S -7A6		
● Generator																	
Frequency	Hz	50	60	50	60	50	60	50	60	50	60	50	60	50	60	50	60
Rated Output	kVA	10.5	13	20	25	37	45	50	60	80	100	100	125	125	150	200	220
Voltage	V	50Hz : 200 or 380 or 400 or 415 , 60Hz : 220 or 440(Dual Voltage)															
Power Factor	%	80															
Class of rating		Continuous															
Exciting Method		Brushless (with A.V.R.)															
No. of Phase		3-Phase , 4-Wire															
● Diesel Engine																	
Make and Model		Kubota D1503-K3A		Kubota V2403-K3A		Kubota V3800-DI-T-K2B		Isuzu BB-4BG1T		Isuzu BI-4HK1X		Isuzu BI-4HK1X		Isuzu BI-6HK1X		Mitsubishi 6D24-TLE2B	
No. of Cylinder		3		4		4		4		4		4		6		6	
Type(4Cycle,Water-Cooled)		Swirl Chamber				Direct Injection,Turbo charged				Direct Injection,Turbo charged,Intercooled							
Total Displacement	L	1.499		2.434		3.769		4.329		5.193		5.193		7.79		11.94	
Rated Output	PS(kW)	15.6(11.5)	18.6(13.7)	26(19.1)	32(23.7)	51.7(38.0)	62(45.6)	65.4(48.1)	78(57.4)	131(96.3)	154(113.6)	131(96.3)	154(113.6)	162(119)	193(142)	246(181)	271(199)
Speed	rpm	1,500	1,800	1,500	1,800	1,500	1,800	1,500	1,800	1,500	1,800	1,500	1,800	1,500	1,800	1,500	1,800
Fuel		Diesel Fuel Oil															
Fuel Tank Capacity	L	95		145		325		400		740		740		815		980	
Fuel Consumption(50/75%Load)	L/hr	1.8/2.4	2.2/3.0	3.0/4.0	3.8/5.0	4.6/6.4	5.7/8.0	6.0/8.6	7.5/10.5	8.9/13.2	12.3/17.8	11/16	15.3/21.8	14.9/22.2	18/24.8	22.5/31.8	26.2/36.3
Continuous operationhours (50/75%Load)	hr	53/40	43/32	48/36	38/29	71/51	57/41	67/47	53/38	83/56	60/42	67/46	48/34	55/37	45/33	44/31	37/27
Lubricating Oil Capacity	L	6.5		9.5		13.2		14.0		20.5		20.5		38		37	
Cooling Water Capacity	L	5.7		7.0		11.0		15.0		21.5		21.5		28.3		39	
Battery(Capacity 5hrs)	(Ah)	80D26R(55)×1		80D26R(55)×1		80D26R(55)×1		80D26R(55)×1		170F51(120)×1		170F51(120)×1		95D31R(64)×2		170F51(120)×2	
● Dimensions & Weight																	
Overall Length	mm	1,480		1,550		1,870		2,050		2,450		2,450		3,190		3,550	
Overall Width	mm	650		700		860		860		1,180		1,180		1,180		1,300	
Overall Height	mm	1,160		1,240		1,590		1,630		1,830		1,830		1,880		2,150	
Net Dry Mass	kg	560		685		1,050		1,290		2,095		2,145		2,725		3,660	
Operating Mass	kg	670		820		1,340		1,650		2,750		2,800		3,460		4,550	
● Sound Level																	
Sound power level in decibels	dB	83		88		85		89		91		92		95		95	
Sound pressure level*1	dB(A)	55	58	59	61	56	58	59	61	60	64	60	64	64	68	66	67

* For other voltages than above-mentioned ones, contact us.

* 1 7m in four directions from machine and at no load

ULTRA SUPER SILENT Environmental Containment Onsite Type SDG-AS-F Series



■ SPECIFICATIONS

Model	SDG25AS -7B1		SDG45AS -7B1		SDG60AS -7A6		
● Generator							
Frequency	Hz	50	60	50	60	50	60
Rated Output	kVA	20	25	37	45	50	60
Voltage	V	50Hz : 200 or 380 or 400 or 415 , 60Hz : 220 or 440(Dual Voltage)					
Power Factor	%	80					
Class of rating		Continuous					
Exciting Method		Brushless (with A.V.R.)					
No. of Phase		3-Phase , 4-Wire					
● Diesel Engine							
Make and Model		Kubota V2403-K3A		Kubota V3800-DI-T-K3A		Isuzu BB-4BG1T	
No. of Cylinder		4		4		4	
Type(4Cycle,Water-Cooled)		Swirl Chamber		Direct Injection,Turbo charged			
Total Displacement	L	2.434		3.769		4.329	
Rated Output	PS(kW)	26(19.1)	32(23.7)	51.7(38.0)	62(45.6)	65.4(48.1)	78(57.4)
Speed	rpm	1,500	1,800	1,500	1,800	1,500	1,800
Fuel		Diesel Fuel Oil					
Fuel Tank Capacity	L	195		325		400	
Fuel Consumption(50/75%Load)	L/hr	3.0/4.0	3.8/5.0	4.7/6.5	5.9/8.2	6.0/8.6	7.5/10.5
Continuous operationhours (50/75%Load)	hr	65/49	51/39	69/49	55/40	67/47	53/38
Lubricating Oil Capacity	L	9.5		13.2		14.0	
Cooling Water Capacity	L	9.0		11.0		15.0	
Battery(Capacity 5hrs)	(Ah)	80D26R(55)×1		80D26R(55)×1		80D26R(55)×1	
● Dimensions & Weight							
Overall Length	mm	1,570		1,995		2,080	
Overall Width	mm	800		950		1,000	
Overall Height	mm	1,380		1,670		1,640	
Net Dry Mass	kg	800		1,210		1,370	
Operating Mass	kg	980		1,500		1,725	
● Sound Level							
Sound power level in decibels	dB	82		82		83	
Sound pressure level*1	dB(A)	51	54	52	54	54	56

* For other voltages than above-mentioned ones, contact us.

* 1 7m in four directions from machine and at no load

ULTRA SUPER SILENT SDG-AS Series



SDG25AS



SDG45AS



SDG60AS



SDG100AS



SDG150AS

■ SPECIFICATIONS

Model	SDG25AS -3B1		SDG45AS -3B1		SDG60AS -3A6		SDG100AS -3A6		SDG150AS -3A6		
● Generator											
Frequency	Hz	50	60	50	60	50	60	50	60	50	60
Rated Output	kVA	20	25	37	45	50	60	80	100	125	150
Voltage	V	50Hz : 200 or 380 or 400 or 415 , 60Hz : 220 or 440(Dual Voltage)									
Power Factor	A	80									
Class of rating	%	Continuous									
Exciting Method		Brushless (with A.V.R.)									
No. of Phase		3-Phase , 4-Wire									
● Diesel Engine											
Make and Model		Kubota V2403-K3A		Kubota V3800-DI-T-K3A		Isuzu BB-4BG1T		Isuzu DD-6BG1T		Hino J08C-UD	
No. of Cylinder		4		4		4		6		6	
Type(4Cycle,Water-Cooled)		Swirl Chamber		Direct Injection,Turbo charged						Direct Injection, Turbo charged,Intercooled	
Total Displacement	L	2.434		3.769		4.329		6.494		7.961	
Rated Output	PS(kW)	26(19.1)	32(23.7)	51.7(38.0)	62(45.6)	65(48.1)	78(57.4)	100(73.6)	124(91.2)	160(118)	190(140)
Speed	rpm	1,500	1,800	1,500	1,800	1,500	1,800	1,500	1,800	1,500	1,800
Fuel		Diesel Fuel Oil									
Fuel Tank Capacity	L	80		165		170		225		265	
Fuel Consumption(50/75%Load)	L/hr	3.0/4.0	3.8/5.0	4.7/6.5	5.9/8.2	6.0/8.6	7.5/10.5	10.2/14.5	13.2/19.0	14.7/19.4	17.7/24.3
Lubricating Oil Capacity	L	9.5		13.2		14		18		24.5	
Cooling Water Capacity	L	9		11		15		24		22	
Battery(Capacity 5hrs)	(Ah)	80D26R(55) ×1		80D26R(55) ×1		80D26R(55) ×1		95D31R(64) ×2		95D31R(64) ×2	
● Dimensions & Weight											
Overall Length	mm	1,570		1,995		2,090		2,700		3,200	
Overall Width	mm	800		950		950		1,140		1,200	
Overall Height	mm	1,090		1,300		1,300		1,500		1,630	
Net Dry Mass	kg	730		1,060		1,280		1,870		2,590	
Operating Mass	kg	810		1,215		1,440		2,100		2,850	
● Sound Level											
Sound power level in decibels	dB	83		82		83		84		88	
Sound pressure level *1	dB(A)	53	56	51	54	55	56	54	57	55	58

* For other voltages than above-mentioned ones, contact us.

* 1 7m in four directions from machine and at no load

■ List of Optional Equipment

● : Standard equipment ○ : Option upon manufacture

Model / Item	SDG13	SDG25	SDG45	SDG60	SDG100	SDG125	SDG150	SDG220	SDG300	SDG400	SDG500	SDG610
Automatic Starting System	○*	○*	○	○	○	○	○	○	○	○	○	○
With built-in battery charger	○*	○*	○	○	○	○	○	○	○	○	○	○
Manual Operated Parallel Operation System	—	—	—	—	F:○ S/AS:—	F:— S:●	F:○ S/AS:●	○	○	○	○	●
Auto-Parallel Operation System	—	—	—	—	—	—	—	○	—	○	○	○
Fuel Auto-feed System	F:— S:○	F:— S/AS:○	F:— S/AS:○	F:— S/AS:○	F:— S/AS:○	F:— S:○	F:— S/AS:○	F:— S:○	○	○	○	○
Three way valve Fuel Feed from outside tank	F:— S:●	F:— S/AS:●	F:— S/AS:●	F:— S/AS:●	F:— S/AS:●	F:— S:●	F:— S/AS:●	F:— S:●	●	●	●	●
Engine Oil Auto-Feed System	—	F/S:○ AS:—	○	○	○	○	○	○	○	○	○	○
Flange at outlet of muffler	○	○	○	○	○	○	○	○	○	○	○	○
Protection against salt damage	○	○	○	○	○	○	○	○	○	○	○	○
Anti-theft cover	○	○	○	○	○	○	○	—	—	—	—	—
Engine Oil Pressure Meter	○	○	○	○	●	●	●	●	●	●	●	●

* Automatic starting system and battery charger cannot be built into at the same time.

General purpose Emergency backup Generator for failure of utility source SDG-E series

When an electric utility outage takes place, the set is automatically switched from the utility source to the backup generator, and when the utility power is restored, it is automatically switched back to the utility power source.

⚡ Three Attempts starting operation

If the engine failed to start up after 10 seconds cranking, additional two more attempts to start will be included to ensure the engine to be started up. "Difficulty in starting" indication lamp will only be on after engine failed to start after three attempts.

⚡ Trial (Test) operation availability

Test operation is available for maintenance and inspection as standard function.

⚡ Built-in Battery charger

ATS panel incorporates a battery charger to keep charging the battery of a standby generator.

⚡ Fault Indication Lamp

Generator fault indication lamp is equipped on the ATS panel. This is a consolidated indication for out of fuel, fuel filter clogging, low engine oil pressure, high coolant temperature, overcurrent and earth leakage.

● Specifications of ATS panel

	For SDG13/25	For SDG45/60	For SDG100/125/150	For SDG220/300	For SDG400/500
Type	Wall mounted type		Floor standing type		
Rated voltage(V)	AC 200/220				
Control voltage(V)	DC 12		DC 24		
L×W×H(mm)	850×550×300	1,000×600×300	1,600×650×300	1,700×800×500	1,700×750×600
Mass(kg)	57	75	125	260/280	300



ATS panel

* ATS panel in photo is ground standing type for outdoor use. (upon customer' request before production process this is available.)

Features and benefits

1. Simplified construction incorporating all required functions
2. Light-weight and compact
3. Easy connection between ATS panel and generator

Examples of Backup Power Supply

- Poultry facilities and Swinery
- Gas-station
- Housing, Villa residence, Office and Factory
- Communication station, Broadcasting station, Lighting facilities and Traffic signal station
- On-line system of bank, Credit union, Agricultural cooperative association
- Battery for portable telephones base
- Facilities for draining water for underground engineering construction

Selection of Optimum Generators

Example of AC arc welder

- AC arc welder is in general single phase load. So when a three phase generator is used for single phase load, it shall be equally connected to three phase.
- Three times more generating power is required for single load welding.

Generators are capable of operating following numbers of arc welders.

Model	SDG25		SDG45		SDG60		SDG100		SDG125		SDG150		SDG220		SDG300		SDG400		SDG500		SDG610	
Frequency(Hz)	50	60	50	60	50	60	50	60	50	60	50	60	50	60	50	60	50	60	50	60	50	60
180A	1	1	3	3	3	5	7	8	10	12	13	14	18	20								
200A		1	2	2	3	4	6	6	8	9	10	11	15	16								
250A			2	2	3	3	5	6	7	8	9	10	14	15								
300A					2	2	3	4	5	6	6	7	10	11	14	17	19	21	24	27	30	33
400A							3	3	3	3	5	5	6	7	9	12	13	14	16	19	21	24
500A									2	3	3	3	5	6	7	10	11	12	13	15	17	18

Note: Numbers of welders in the above table are for such ones without condensers equipped for reference purpose only. When using generators for extremely low efficient welders, reduce the numbers of welders. When using generators for AC arc welders equipped with condenser, it is necessary to be very careful for self-exciting phenomena (Output voltage of generator extremely increases in case of no load or light load). The above table shows the numbers of welders when operating 40%. In case of more Percentage than 40%, reduce the numbers of welders. When using generators for more welders than 2 units, connect evenly it to each welder, not concentrating one unit only.

Example of electric motors (three-phase squirrel-cage motor)

Engine generators are used for large and small various type electric motors. In general capacity of electric motor is specified in kW or PS. This shows motor output capacity, not motor input capacity or not required to operate motor (machine). The relation between motor output and input is shown in the following formula.

1 PS = 0.7355 kW
 Efficiency = 85% (three phase induction motor)
 Power factor = 0.8 (three phase induction motor)

$$\frac{\text{Output(kW)}}{\text{Efficiency}} = \frac{0.7355 \times \text{Output(PS)}}{\text{Efficiency}} = \text{Input(kW)}$$

$$\frac{\text{Input(kW)}}{\text{Power factor}} = \text{Input(kVA)}$$

Motor starting capacity

Model	SDG13		SDG25		SDG45		SDG60		SDG100		SDG125		SDG150	
Frequency(Hz)	50	60	50	60	50	60	50	60	50	60	50	60	50	60
Generator(kVA)	10.5	13	20	25	37	45	50	60	80	100	100	125	125	150
Motor capacity	Direct start		Simultaneously(kW)		By turns(kW)		λ-Δ start(open)(kW)		λ-Δ start(closed)(kW)					
	4	4.5	6.5	7.5	12	14	17	19	26	32	35	43	43	51
	7.5	9	15.1	18.8	27.9	34	37.7	45.3	60.4	75.5	75.5	94.4	94.4	113
	6	6.8	9.8	11.3	18	21	22.5	28.5	39	48	52.5	64.5	64.5	76.5
	7.5	9	15.1	18.8	27.9	34	37.7	45.3	60.4	75.5	75.5	94.4	94.4	113

Model	SDG220		SDG300		SDG400		SDG500		SDG610	
Frequency(Hz)	50	60	50	60	50	60	50	60	50	60
Generator(kVA)	200	220	270	300	350	400	450	500	555	610
Motor capacity	Direct start		Simultaneously(kW)		By turns(kW)		λ-Δ start(open)(kW)		λ-Δ start(closed)(kW)	
	68	76	91	102	130	145	160	181	180	190
	147	166	188	226	265	302	340	377	415	453
	102	114	137	153	195	218	240	272	270	285
	147	166	188	226	265	302	340	377	415	453

- * The motor capacities in the above table are only for reference purpose. The generator capacities vary upon instantaneous voltage drop, motor start class, efficiency, old and new type machine.
- The instantaneous voltage drop when motor starts shall be within 30% of no load voltage. ● Motor starting kVA shall be 7 kVA per one (1) kW.
- Motor efficiency shall be 85% and load 90%.
- When operating many motor loads (starting by turns one by one) and total capacity of the loads within the values in the above table, it can operate as many loads as expected. But the total capacity of the motors which are operated first shall be within the capacity at direct start instantaneous start.
- The engine load of the engine complete with turbo-charger sometimes may be influenced by engine net average efficient pressure.

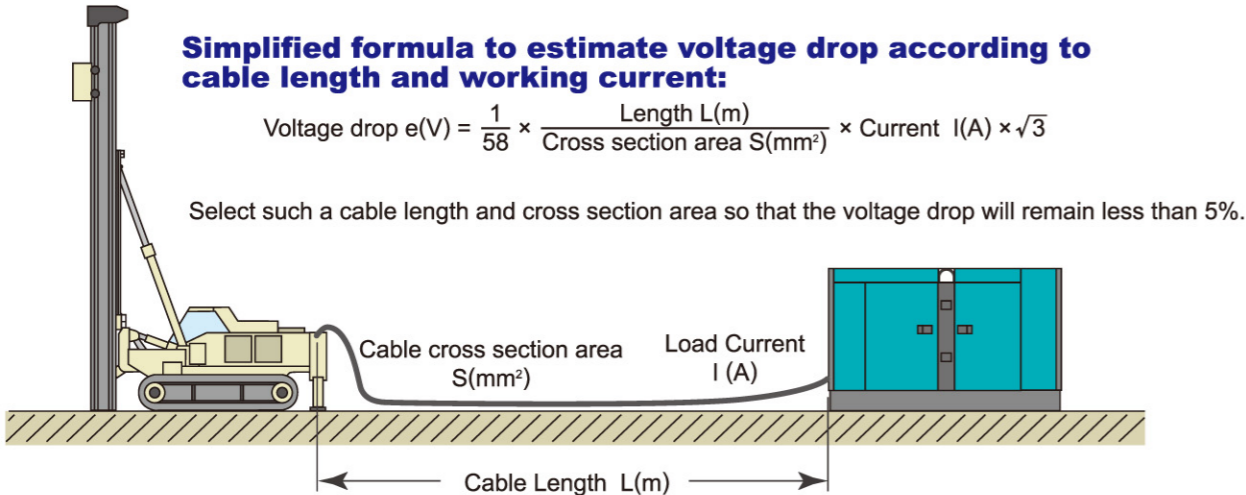

List of current values at a glance

Model	SDG13	SDG25	SDG45	SDG60	SDG100	SDG125	SDG150	SDG220	SDG300	SDG400	SDG500	SDG610
50Hz	200V	30.3	57.7	107	144	231	289	361	563	779	1,010	1,299
	380V	16.0	30.4	56.2	76.0	122	152	190	296	410	532	684
	400V	15.2	28.9	53.4	72.2	115	144	180	281	390	505	650
60Hz	220V	34.1	65.6	118	157	262	328	394	577	787	1,050	1,312
	440V	17.1	32.8	59.0	78.7	131	164	197	289	394	525	656

List of Neutral Point (O terminal) Allowable Power

Model	SDG13		SDG25		SDG45		SDG60		SDG100		SDG125		SDG150	
Frequency(Hz)	50	60	50	60	50	60	50	60	50	60	50	60	50	60
● 200/220V														
Voltage(V)	115	127	115	127	115	127	115	127	115	127	115	127	115	127
Allowable ampere 3 phase average(A)*1	30.3	34.1	57.7	65.6	107	118	144	157	231	262	289	328	361	394
Output ratio	100*2													
Allowable ampere Single phase(A)*	30.3	34.1	57.7	65.6	107	118	144	157	115	131	144	164	180	197
Output ratio	100*2						100*2							
● 400(380)/440V														
Voltage(V)	(231)	254	(231)	254	(231)	254	(231)	254	(231)	254	(231)	254	(231)	254
Allowable ampere 3 phase average(A)*1	(15.2)	17.1	(30.4)	32.8	(53.5)	59.0	(72.0)	78.5	(115.5)	131	(144)	164	(180)	197
Output ratio	100*2													
Allowable ampere Single phase(A)*	(15.2)	17.1	(28.9)	32.8	(53.5)	59.0	(72.0)	78.5	(67.9)	65.0	(72.0)	82.0	(80.0)	98.0
Output ratio	100*2						50*3							

Model	SDG220		SDG300		SDG400		SDG500		SDG610	
Frequency(Hz)	50	60	50	60	50	60	50	60	50	60
● 200/220V										
Voltage(V)	115	127	115	127	115	127	115	127	115	127
Allowable ampere 3 phase average(A)*1	450	462	623	630	808	840	1,039	1,050	1,282	1,280
Output ratio	80*4									
Allowable ampere Single phase(A)*	563	577	779	787	1,010	1,050	1,299	1,312	1,602	1,600
Output ratio	100*2									
● 400(380)/440V										
Voltage(V)	(231)	254	(231)	254	(231)	254	(231)	254	(231)	254
Allowable ampere 3 phase average(A)*1	(225)	231	(318)	315	(425)	420	(529)	525	(671)	640
Output ratio	80*4									
Allowable ampere Single phase(A)*	(281)	289	(390)	394	(505)	525	(650)	656	(801)	800
Output ratio	100*2									

- *1 When you use single phase with O terminal at the same time for each phase from Model SDG13S/25S/AS to SDG150S/AS, the unbalance of current value for each phase should be kept within 50%. When the current values exceed the limit, please note that the output voltages for each phase may be unbalanced.
- *2 Output ratio shows an allowable output figure of the rated current. (Rated output 100% = it is allowable to use the rated current value until 100%.)
- *3 Output ratio shows an allowable output figure of the rated current. (Rated output 50% = it is allowable to use the rated current value until 50%.)
- *4 Output ratio shows an allowable output figure of the rated current. (Rated output 80% = it is allowable to use the rated current value until 80%.)

Leakage Protection Device and Grounding Method

Leakage Protection Device

This machine is equipped with a leakage relay which detects leakage caused by a defective insulation of working load to prevent an accident such as an electric shock by shutting down the circuit. However, for additional safety, install ground fault circuit interrupter (GFCI) for each load equipment close to the load equipment. The sensitivity current of the leakage relay is 30mA.

Grounding Method

<Procedure>

1. Connect a lead wire fitted with a ground rod to the leakage relay grounding terminal (E) of the three-phase output terminal board.
2. Connect the generator machine ground terminal of the package to ground.
3. Be sure to ground the package of the load equipment as well.
3. These grounding must be carried out in accordance with local regulations.

